

# GB-35

## Great Basin™ GREASE INTERCEPTOR TECHNICAL DATA

Submittal | Specifications | Installation | Application Specific Details

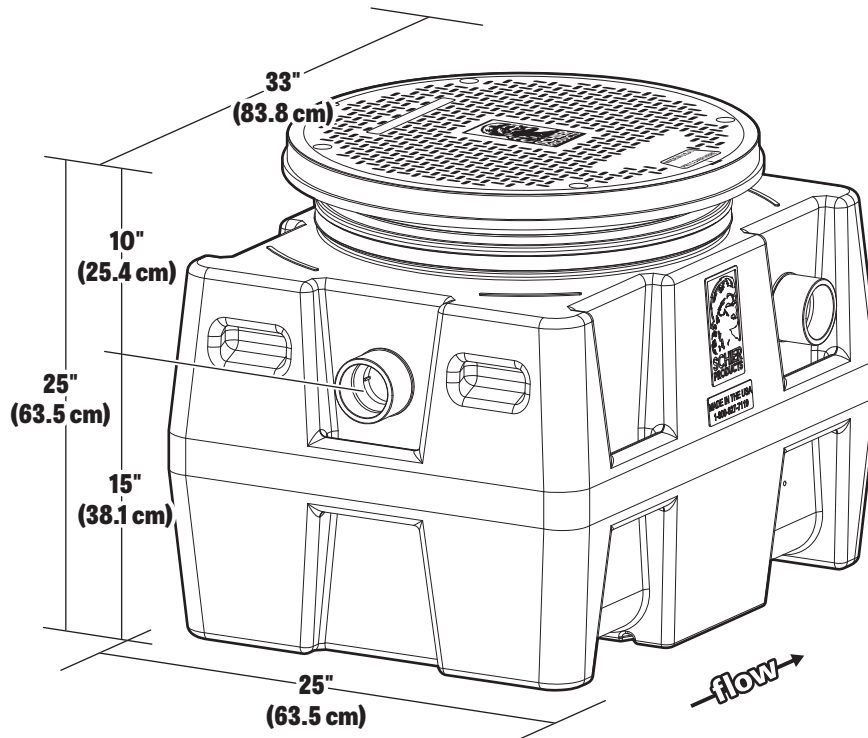

## SUBMITTAL

**STANDARD:** 3" plain end inlet/outlet | Capacities - Liquid: 35 gal.; Grease: 142 lbs. (20 gal.); Solids: 9.5 gal.  
Pedestrian load rated, bolted, gas/water tight composite cover. (2,000 lbs.)

### OPTIONS:

- 2" Plain End Inlet/Outlet
- 2" Male Thread Inlet/Outlet
- 3" Male Thread Inlet/Outlet
- 4" Plain End Inlet/Outlet
- 4" Male Thread Inlet/Outlet
- Integral Membrane Clamping Collar Kit
- Pumpout Port (Small)

### TeleGlide Risers

- SR24** >3-1/2" - 22"
- LR24** >22" - 37"

### APPROVAL:

Signature:
Date:
Company:
Specifying Engineer:
Engineering Firm:



**SCHIER**  
LIFETIME GUARANTEED  
GREASE INTERCEPTORS

**MODEL NUMBER:**  
**GB-35**

**DESCRIPTION:** Polyethylene Grease Interceptor  
35 GPM - 35 gallon capacity

**PART #:** 4020-001-XX

**DWG BY:** C. O'Boyle

**DATE:** 10/08/2015

**REV:** 0 / / 201\_

**ECO:**

# SPECIFICATIONS

## NOTES

- 3" plain end inlet/outlet
- Unit weight - w/composite cover: 77 lbs.
- Maximum operating temperature: 190° F continuous
- Capacities - Liquid: 35 gal.; Grease: 142 lbs. (20 gal.); Solids: 9.5 gal.
- Built-in Flow control.
- For gravity drainage applications only.
- Do not use for pressure applications.
- Cover placement allows full access to tank for proper maintenance.
- Vent not required unless per local code.
- Engineered inlet and outlet diffusers are removable to inspect/clean piping.
- Integral air relief / Anti-siphon

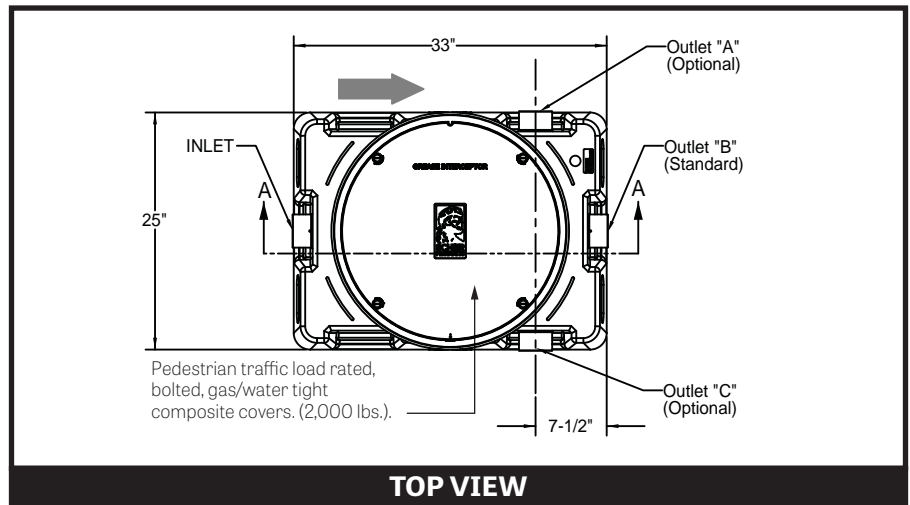

**TOP VIEW**

## DIFFUSION FLOW TECHNOLOGY

The inlet diffuser splits influent into three paths, creating laminar flow and utilizing the entire liquid volume of the tank for efficient grease separation. The calibrated openings greatly reduce effluent turbulence. The effluent enters the main chamber without disturbing the existing grease or sediment layers.

The integral air relief / anti-siphon in the top of the outlet diffuser allows pressure stabilization within the unit during operation. The bottom of the outlet diffuser allows only effluent which is free of grease to exit the tank. It can easily be attached to any of the three outlets provided to ease jobsite piping layouts.

## ENGINEER SPECIFICATION GUIDE

Schier Great Basin™ grease interceptor model # GB-35 shall be lifetime guaranteed and made in USA of seamless, rotationally-molded polyethylene. Interceptor shall be furnished for above or below grade installation. Interceptor shall be certified to ASME A112.14.3 (type C) and CSA B481.1, with field adjustable riser system, built-in flow control, built-in test caps and three outlet options. Interceptor flow rate shall be 35 GPM. Interceptor grease capacity shall be 142 lbs. Cover shall provide water/gas-tight seal and have minimum 2,000 lbs. load capacity.

## CERTIFIED PERFORMANCE

Great Basin hydromechanical grease interceptors are third party performance-tested and listed by IAPMO to ASME #A112.14.3 and CSA B481.1 grease interceptor standards and greatly exceed requirements for grease separation and storage. They are compliant to the Uniform Plumbing Code and the International Plumbing Code.

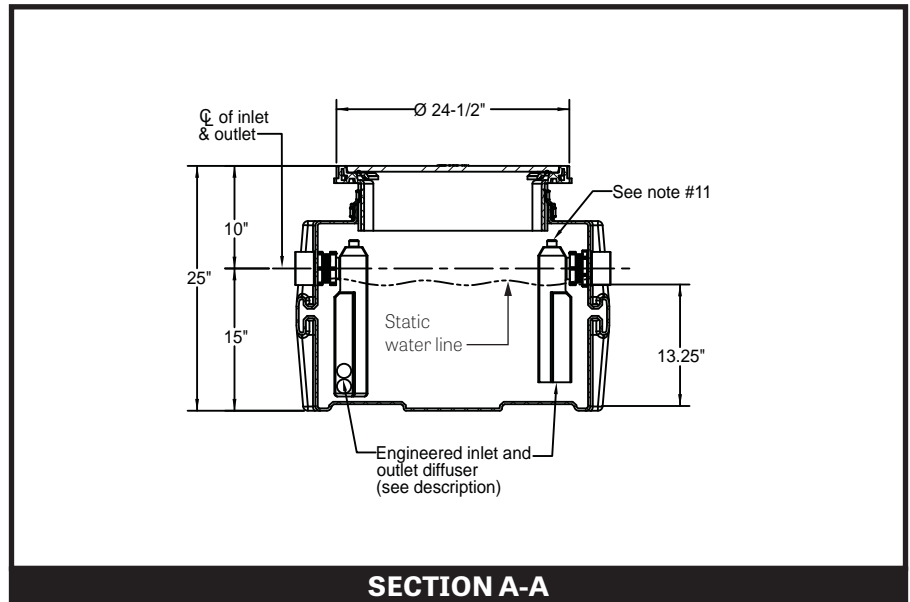

**SECTION A-A**

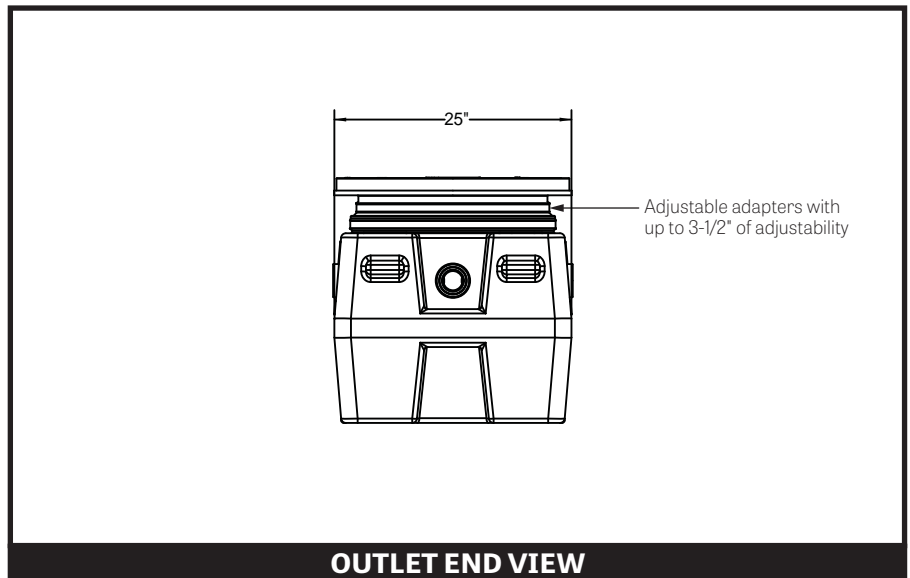

**OUTLET END VIEW**

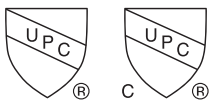

**SCHIER**  
LIFETIME GUARANTEED  
GREASE INTERCEPTORS

MODEL NUMBER:  
**GB-35**

DESCRIPTION: Polyethylene Grease Interceptor  
35 GPM - 35 gallon capacity

PART #: 4020-001-XX

DWG BY: C. O'Boyle

DATE: 10/08/2015

REV: 0 / / 201\_

ECO:

# INSTALLATION (1 of 2)

**WARNING! DO NOT AIR TEST UNIT OR TELEGLIDE RISER SYSTEM!** Doing so may result in property damage, personal injury or death.

## LEAK/SEAL TESTING

Cap/plug all base unit plumbing connections and remove covers. **For base unit testing**, fill with water to just above the highest connection. **For riser system testing** (if required) fill with water to finished grade level. **CAUTION: Risers must be supported before filling with water to prevent tipping.** Inspect unit, connections and all gaskets and clamps (if applicable) for leaks. Check water level at specific time intervals per local code.

## GENERAL INSTALLATION INSTRUCTIONS

Schier grease interceptors are manufactured with an internal flow control system. They do not require an external flow control system or air intake vent. Schier grease interceptors are not to be installed in any other manner except as shown. Consult local codes for separate trapping requirements, cleanout locations and additional installation instructions.

1. Set unit on level solid surface as close as possible to fixtures being served.
2. Connect outlet diffuser to the desired outlet (A,B,C). Unit is shipped with the outlet diffuser in location B and sealing caps on locations A and C.
3. Connect inlet and outlet drainage lines to unit. Mechanically couple pipes to unit. **Do not solvent weld.**

**NOTE:** Do not install below a hydrostatic slab.

## BELOW GRADE INSTALLATION INSTRUCTIONS

### EXCAVATION

1. Surrounding soil must be undisturbed soil or well compacted engineering fill.
2. Width and length of excavation shall be a minimum of 12" greater than the tank and depth shall be 6" deeper than tank bottom.
3. Set the tank level on a 6" deep layer of well-packed crushed aggregate material and connect waste piping per General Installation Instructions.

### BACKFILL

1. Preparation of sub grade per geotech recommendations.
2. Stabilize and compact sub grade to 95% proctor.
3. Fill unit with water before backfilling to stabilize unit and prevent float-out during backfilling. Secure covers and risers (if necessary) to the unit.
4. Backfill evenly around tank using crushed aggregate (approximately 3/4" size rock or sand, with no fines), or flowable fill. **Do not compact backfill around unit.**

### FINISHED CONCRETE SLAB

Slab must extend 18" minimum outside the unit footprint.

**Pedestrian traffic or greenspace areas:** 4" Thick reinforced concrete slab required.

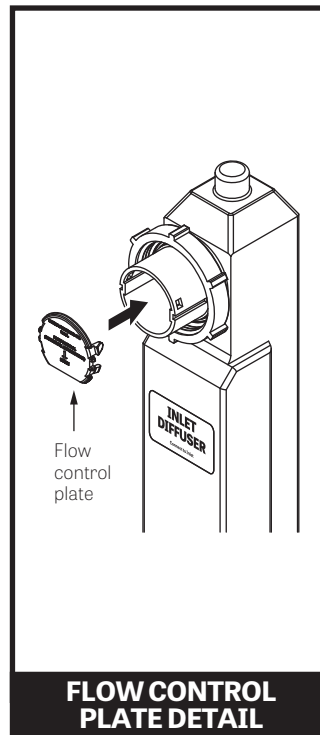

**FLOW CONTROL PLATE DETAIL**

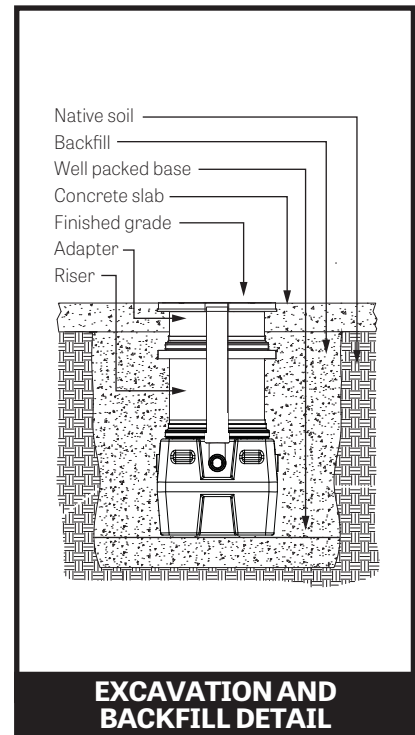

**EXCAVATION AND BACKFILL DETAIL**

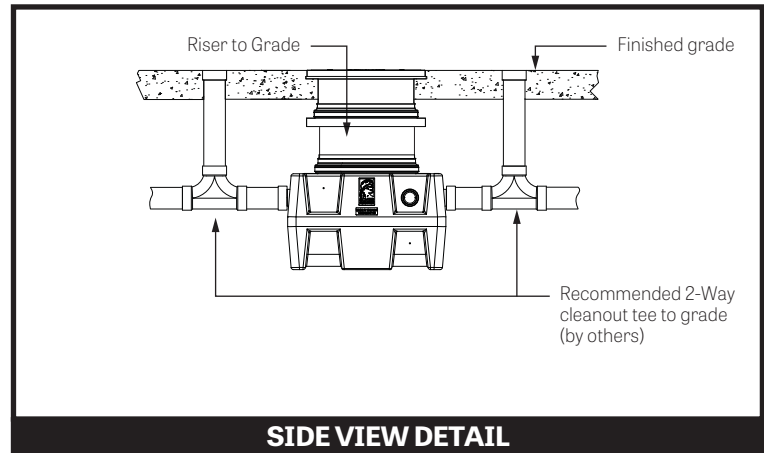

**SIDE VIEW DETAIL**

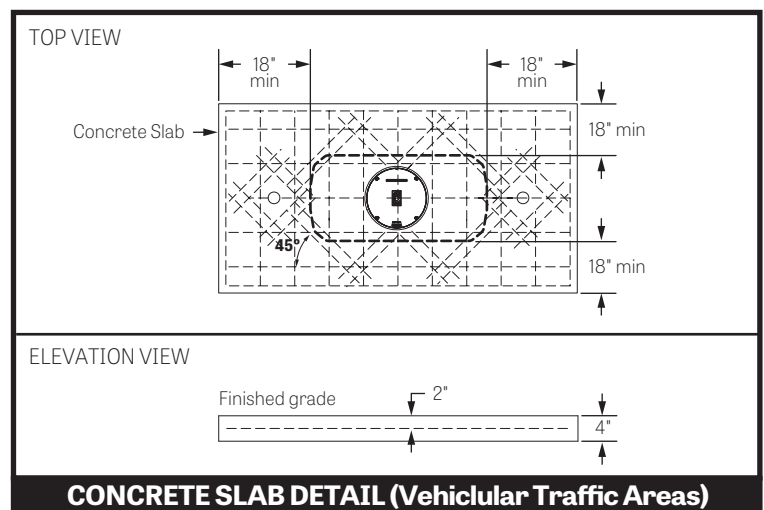

**SCHIER**  
LIFETIME GUARANTEED  
GREASE INTERCEPTORS

MODEL NUMBER:  
**GB-35**

DESCRIPTION: Polyethylene Grease Interceptor  
35 GPM - 35 gallon capacity

PART #: 4020-001-XX

DWG BY: C. O'Boyle

DATE: 10/08/2015

REV: 0 / / 201\_

ECO:

# INSTALLATION (2 of 2)

## TELEGLIDE RISER (24 SERIES) INSTALLATION GUIDELINES

**Tools needed:** 7/16" Nut driver tool/bit (included), marker (included), tape measure and drill with 1/2" chuck. Jigsaw, circular saw or reciprocating saw will be needed if risers need to be cut.

**NOTE:** To remove a component or adjust its position, the Upper Band Clamp needs to be loosened or removed using nut driver bit. Loosened clamps should be retightened to 5 - 8 ft lbs. of torque (same as a rubber no-hub coupling). The Lower Band Clamp is factory set and should not be adjusted or removed.

### Riser Assembly Instructions/Steps

1. Set unit so the pipe connections line up with jobsite piping and measure riser height needed from top of cover to finished grade. See Table 1 to select risers needed.
2. Remove covers from adapters. Remove adapters from main unit. On a level surface, pre-assemble the risers and adapters, adjusting the components upwards or downwards to achieve the riser height needed. Make sure to maintain minimum and maximum insertion depths as shown in Figure 2. If components are too long, make a circular line around the sidewall with marker and cut with a power saw. The lowest cut line on the riser assembly will be 5" beyond the riser height needed to allow for ideal insertion depth (See Figure 1). An alignment mark should be drawn 1-2" beyond the riser height needed (depending on connection size) which will align with the top of the base unit gasket. **DO NOT** cut the alignment mark. The Adapters and risers should sit level with each other. Tighten upper clamps to keep riser/adaptor assembly from shifting. Make alignment marks on the sidewalls at the top of all riser gaskets to aid final assembly.
3. **IMPORTANT:** Before the next step, make sure both diffusers are installed inside the main unit at the appropriate locations. Check if there needs to be any flow control adjustment at the inlet diffuser (see general installation instructions).
4. Take apart riser assembly and clean all sidewalls and insides of gaskets to remove dust/debris. Install components into the main unit starting from the lowest riser and work your way up to finished grade. Maintain minimum and maximum insertion depths for all components (see Figure 2). Tighten Upper Clamps to specified torque after correctly positioning components. Riser assembly may need to be supported during backfill.
5. If tilting of the adapter is required to be flush with grade, do so **AFTER** all clamps have been tightened with riser(s)/adaptor in a vertical and level position. Tilting is done using gasket flexibility. Tilting before tightening clamps may ruin a perfect gasket seal. Schier recommends tilting only the adapter versus the entire riser assembly to make sure your riser height and proper tank access is maintained.
6. If riser height conditions change after completing above steps, there may be room for adjustment. As long as minimum and maximum insertion depths are maintained (see Figure 2), the adapters/risers can be adjusted/cut as many times as necessary. When riser system installation is complete, see Leak/Seal Testing procedure if required (p3 of 5).

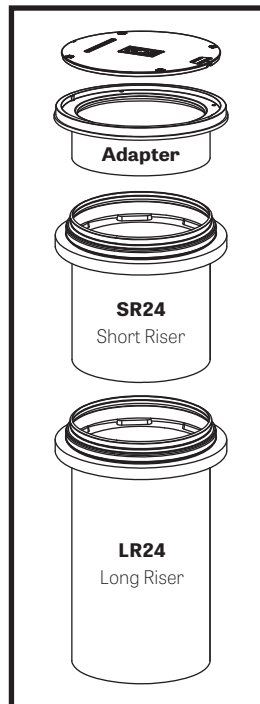

**TeleGlide Riser Components**

**Table 1**

Riser Height Needed	Risers Required
0 - 3-1/2"	None (use adapter)
>3-1/2" - 22"	SR24
>22" - 37"	LR24

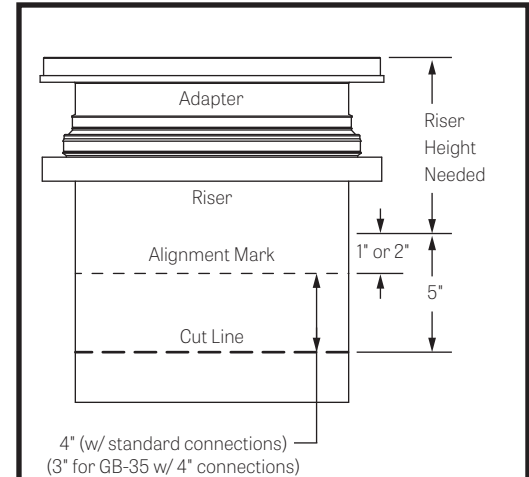

**Figure 1 - Riser Measurements**

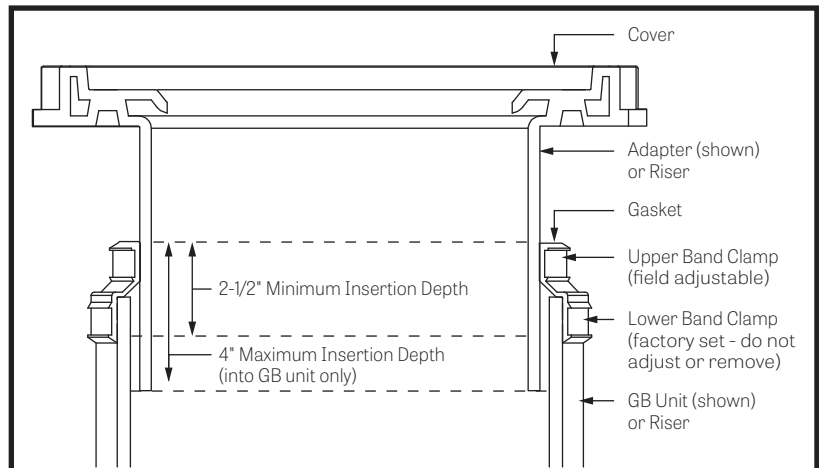

**Figure 2 - Insertion Depths**



**SCHIER**  
LIFETIME GUARANTEED  
GREASE INTERCEPTORS

**MODEL NUMBER:**  
**GB-35**

**DESCRIPTION:** Polyethylene Grease Interceptor  
35 GPM - 35 gallon capacity

**PART #:** 4020-001-XX

**DWG BY:** C. O'Boyle

**DATE:** 10/08/2015

**REV:** 0 \_\_\_/\_\_\_/201\_

**ECO:**

# APPLICATION SPECIFIC DETAILS

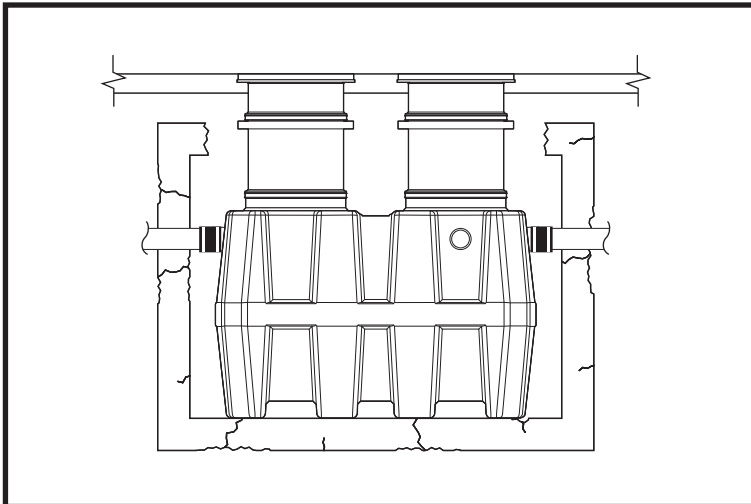

Inside a Corroded Concrete Unit

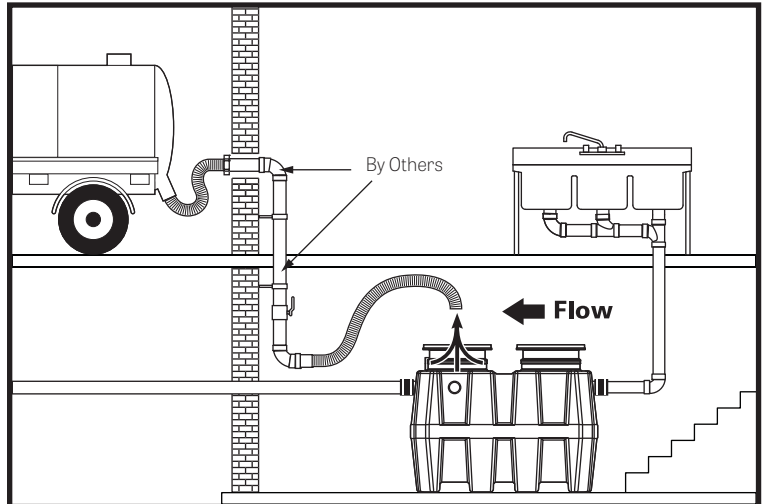

Basement Installation with Remote Pump-out

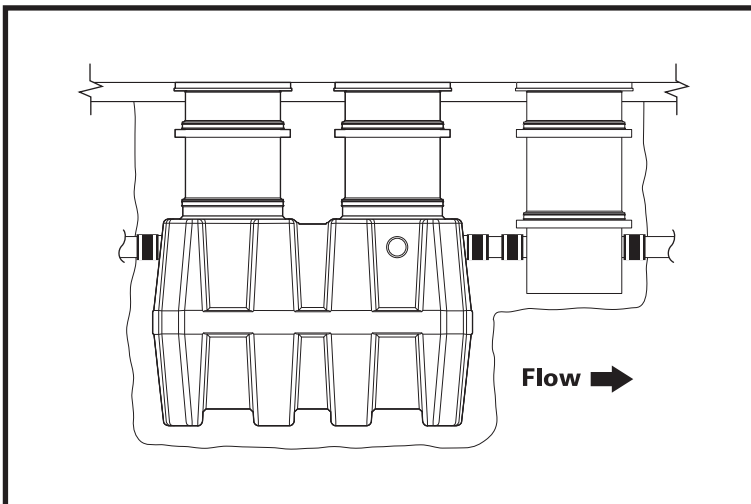

Installation with Sampling Port SV24-L4

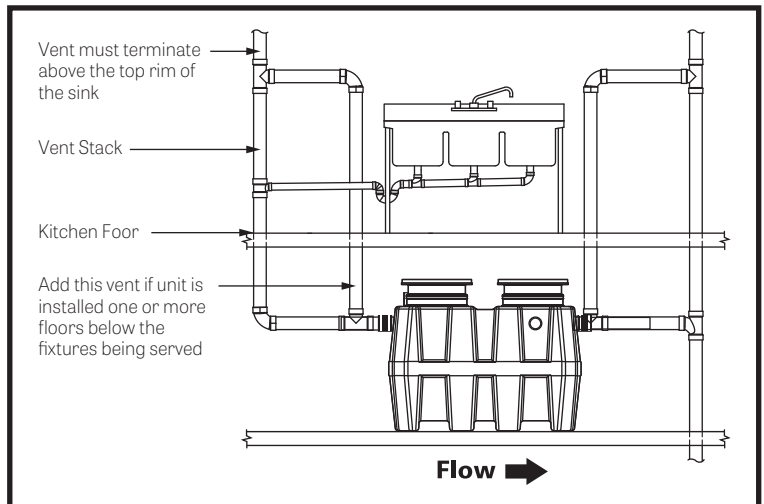

Additional Venting for Floor-Below Installations

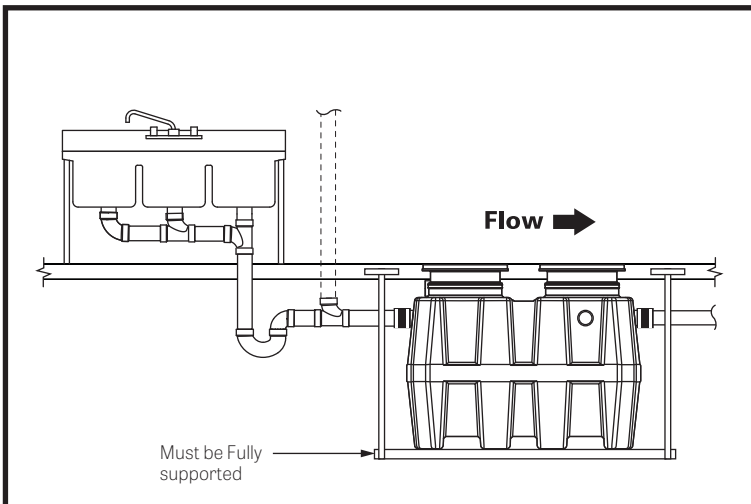

Recessed and Suspended



**SCHIER**  
LIFETIME GUARANTEED  
GREASE INTERCEPTORS

MODEL NUMBER:  
**GB-35**

DESCRIPTION: Polyethylene Grease Interceptor  
35 GPM - 35 gallon capacity

PART #: 4020-001-XX

DWG BY: C. O'Boyle

DATE: 10/08/2015

REV: 0 / / 201\_

ECO: